



**ARR**

ARRIAGA STONE  
EXCLUSIVE



# AR

## NATURAL STONE

Es única y misteriosamente irrepetible, pero a su vez cercana y natural. Entre sus formas guarda oculta la historia de otra enorme piedra de la que forma parte: La Tierra.

Acaríciala, siéntela... porque jamás verás otra igual.

Es única y misteriosamente irrepetible, pero a su vez cercana y natural. Entre sus formas guarda oculta la historia de otra enorme piedra de la que forma parte: La Tierra.

Acaríciala, siéntela... porque jamás verás otra igual.

ARRIAGA STONE  
EXCLUSIVE



# FIRE PLACES MODERN COLLECTION / DESIGNED BY JOSEP GUIU / ARRIAGA STONE EXCLUSIVE PRODUCT

Un único objetivo nos ha guiado en el camino nada fácil de la creación: romper la percepción clásica del mármol y buscar la esencia de los materiales, de las formas, del entorno... El resultado, una familia de chimeneas modernas que amplían las posibilidades de versatilidad, ofreciendo una adaptación sencilla, natural e innovadora que da vida al protagonista... El fuego.

A single aim has guided us along the never easy path of creating: to break with the traditional perception of marble, and find the essence of materials, of shapes and surroundings...

The result is a line of modern fireplaces which extend opportunities for versatility, offering a simple, natural and innovative method of adaption that breathes life into the star element... Fire.

## MODIS

Con Modis comienza una colección de formas geoméricamente simples. Su suave curva, un diseño que nace de la pared y avanza despegándose de ella poco a poco, marca el espacio natural de la chimenea, creada con dos materiales diferentes.

Modis puede articularse tanto en horizontal como en vertical.

Porque Modis se amolda... a ti.

Modis is the start of a collection with simple geometric shapes. With soft curves, a design that starts at the wall, slowly unfolding away from it, frames the natural area for a fireplace, made with two different materials. Modis can be either horizontal or vertical in layout. Because Modis shapes itself... to what you want.

ARRIAGA STONE  
EXCLUSIVE



ARRIAGA STONE  
EXCLUSIVE







## SUN

La chimenea se integra en la pared y se combina con módulos planos alrededor de su boca redonda que, aunque a primera vista evoca naturalidad y sencillez, advierte de lo distintivo y excepcional de su naturaleza. La pieza puede sobresalir o enrasarse a la pared, creando una sensación original de horizontalidad o verticalidad.

Si alguna vez has soñado con tener al sol en tu casa, ahora puedes hacer que no se vaya nunca.

The fireplace is set into the wall and combines with flat modules around the round opening which, although may seem natural and simple at first sight, shows what makes it different and exceptional. The piece can stand out from the wall or lie flush with it, creating an original sensation of being horizontal or vertical.

If you have ever wanted to keep the sun in your home, now you need never let it go away.

ARRIAGA STONE  
EXCLUSIVE



ARRIAGA STONE  
EXCLUSIVE





## MOON

Su corte, caprichoso como la luna, combina materiales y juega a dos alturas, pudiendo montarse por sus cuatro costados, creando resultados perceptivos extraordinariamente diferentes. Déjate envolver por la desconocida calidez de la luna...

With a style as capricious as the moon, a combination of two materials and a play of two heights, this can be mounted on all four sides, creating truly different perceptions. Let yourself be enveloped in the unknown warmth of the moon...

ARRIAGA STONE  
EXCLUSIVE



ARRIAGA STONE  
EXCLUSIVE









## CUBIC

No sólo es única por su geometría cuadrada y estudiada, sino porque cada uno de sus cuadrantes contiene a su vez otro cuadrante de hogar. Predomina la línea curva sobre el ángulo recto, acercando el calor hacia nosotros, empujado por una especie de atracción mutua e inevitable.

This is not only unique for its square, finely designed shape, but also because each quarter part contains, in turn, another quarter of the fireplace. Curved lines predominate over right angles, bringing you warmth, driven by a kind of mutual and inevitable attraction.

ARRIAGA STONE  
EXCLUSIVE



ARRIAGA STONE  
EXCLUSIVE





## L4 SERIES

La L4 aporta al calor del fuego un elemento mobiliario imprescindible, el banco. Jugando con la flexibilidad del material, evoca las costumbres de antaño de reunirse alrededor del fuego para charlar o descansar en silencio. Porque las tradiciones no deben perderse, pero pueden renovarse.

L4 combines the warmth of fire with an essential piece of furniture, the bench. Playing with the flexibility of the material, times past are remembered, when everyone would gather round the fireplace to chat or rest in silence. Traditions should not be lost, but can be renewed.

ARRIAGA STONE  
EXCLUSIVE

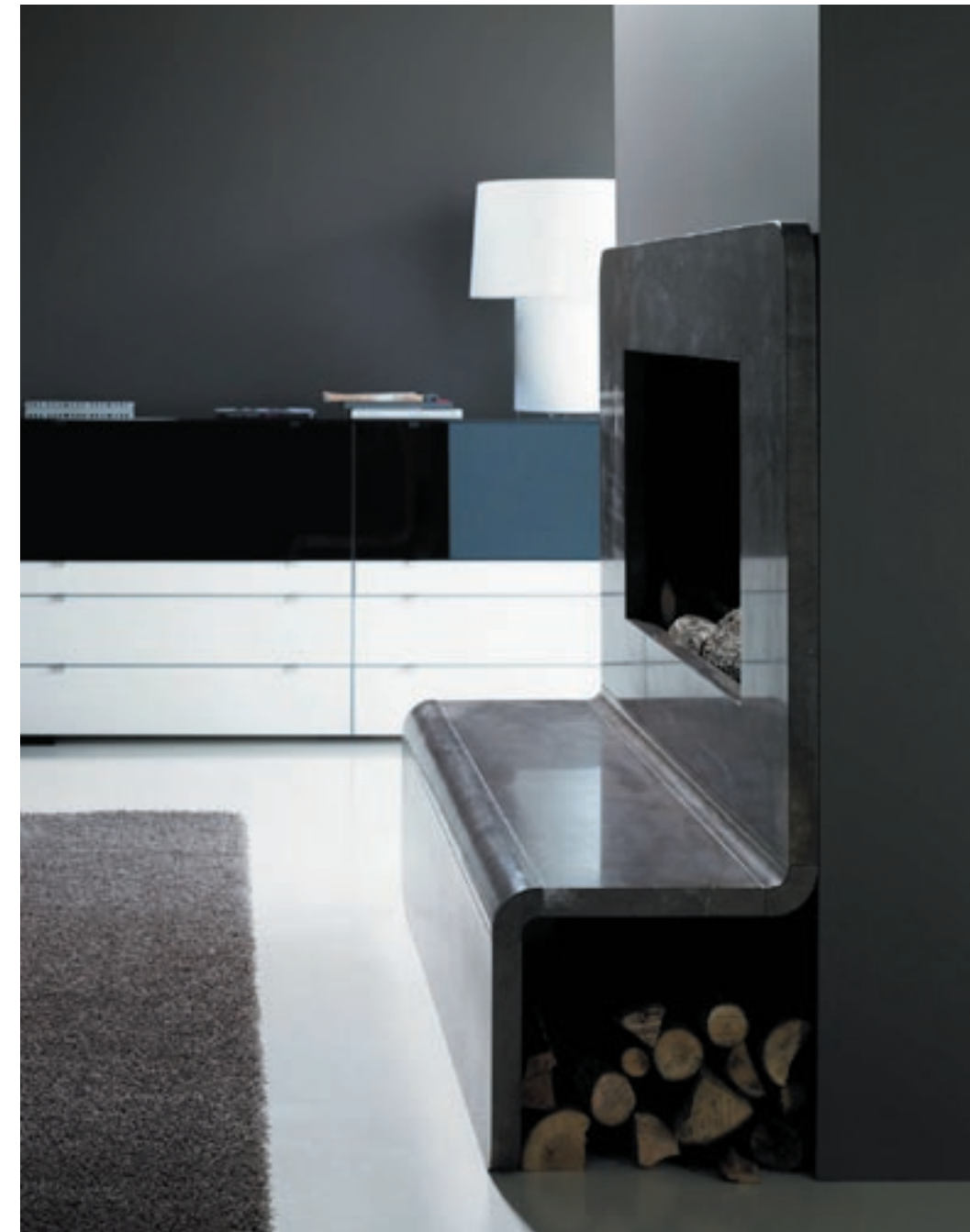

ARRIAGA STONE  
EXCLUSIVE





## L SERIES

Su originalidad y la sencillez de su diseño permite colocarlas en horizontal o vertical, según el espacio del que dispongamos. Al igual que la L4, esta chimenea pretende dar al mármol una flexibilidad elegante, pensada para ocupar muy poco espacio visual. Y es que menos, es más...

The originality and simplicity of its design means it can be positioned horizontally or vertically, depending on the space available. As with the L4, this fireplace provides marble with a flexible elegance, designed to take up very little space visually. Less is more...

ARRIAGA STONE  
EXCLUSIVE



ARRIAGA STONE  
EXCLUSIVE







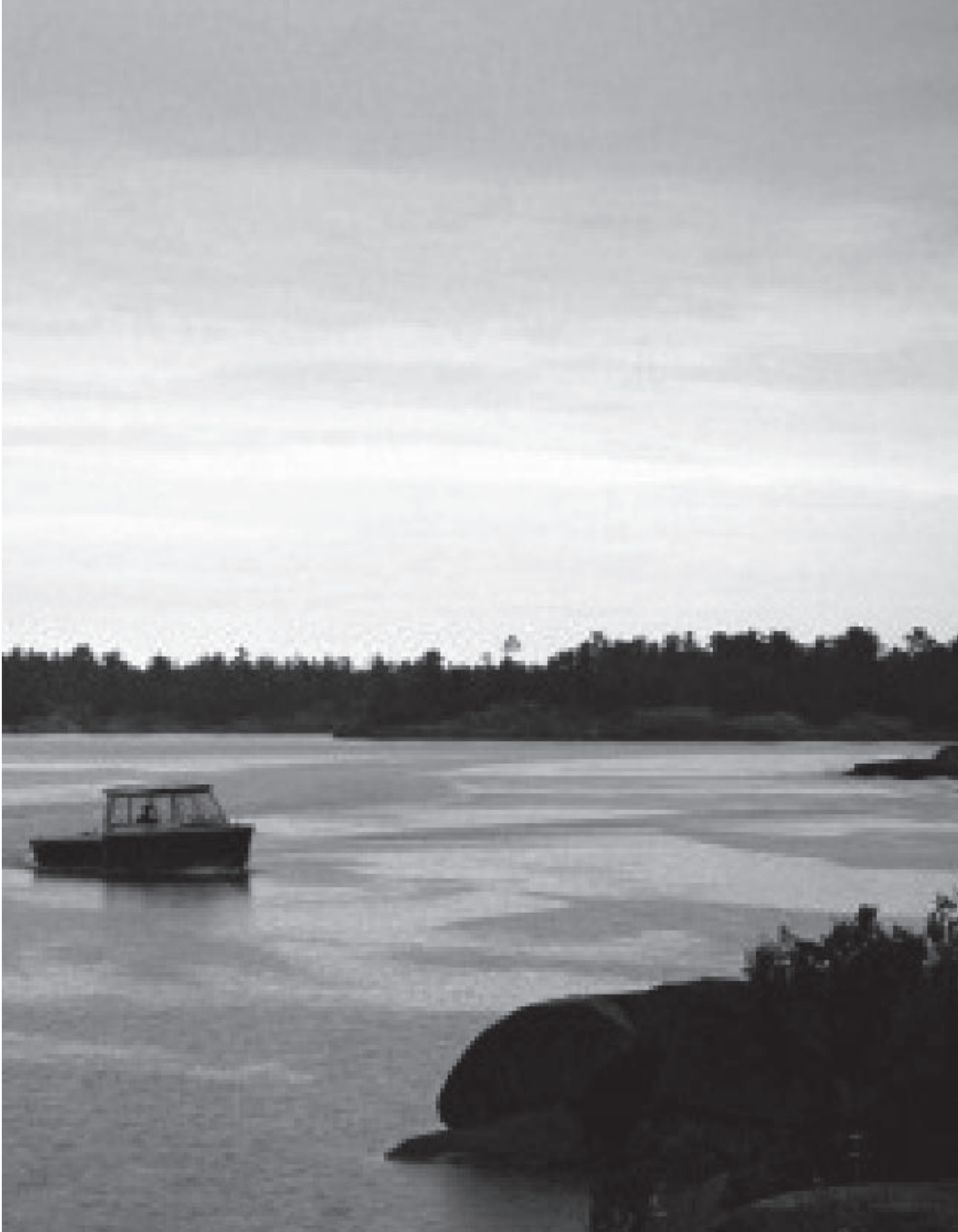

MY HOME

Unica e irrepitible, tan solo es un trozo de otra enorme piedra. La Tierra.

ARRIAGA STONE  
EXCLUSIVE

MODIS

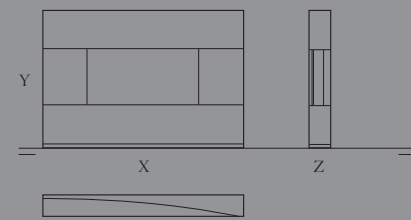

Medidas / Measurements 180 x 120 x 20  
Centímetros / Centimetres

Posibles configuraciones /  
Another configurations

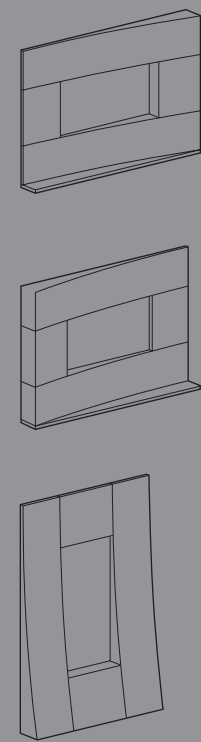

SUN

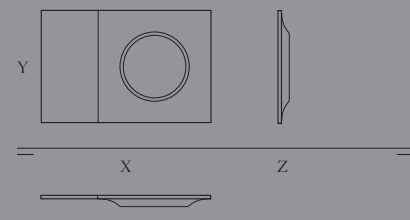

Medidas / Measurements 150 x 100 x 10  
Centímetros / Centimetres

Posibles configuraciones /  
Another configurations

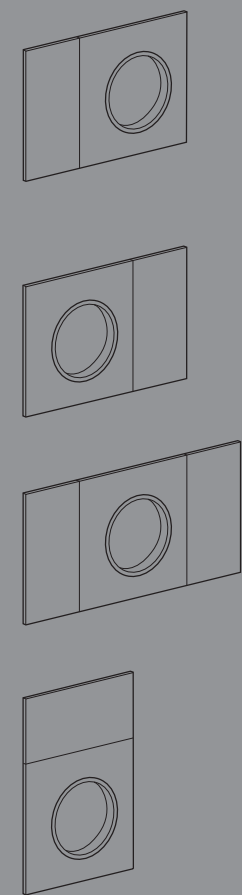

MOON

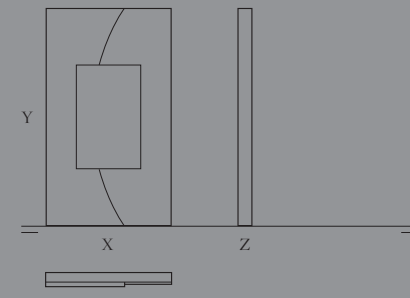

Medidas / Measurements 110 x 190 x 12  
Centímetros / Centimetres

Posibles configuraciones /  
Another configurations

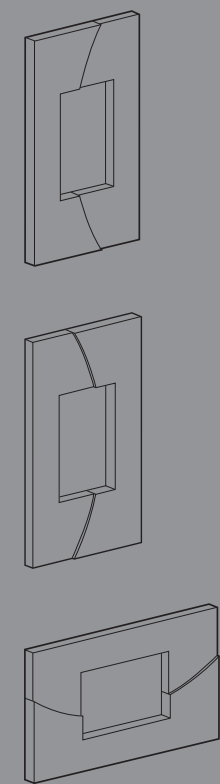

CUBIC

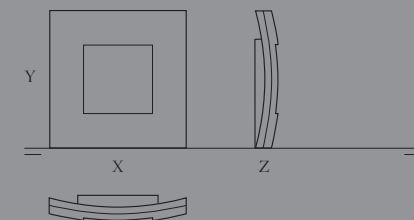

Medidas / Measurements 120 x 120 x 22  
Centímetros / Centimetres

Posibles configuraciones /  
Another configurations

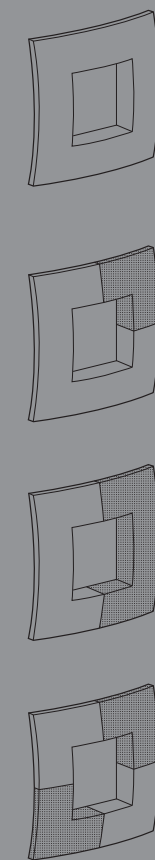

L4 SERIES

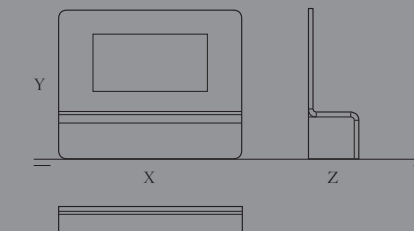

Medidas / Measurements X x Y x Z  
Centímetros / Centimetres

Posibles configuraciones /  
Another configurations

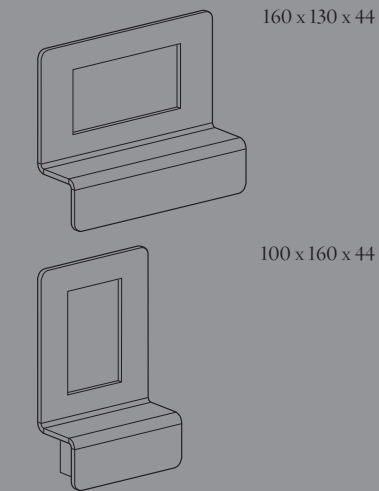

L SERIES

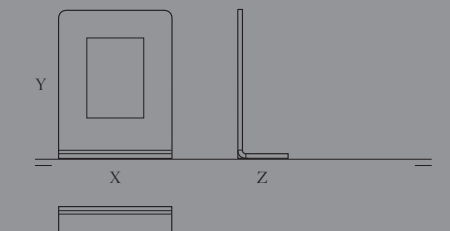

Medidas / Measurements X x Y x Z  
Centímetros / Centimetres

Posibles configuraciones /  
Another configurations

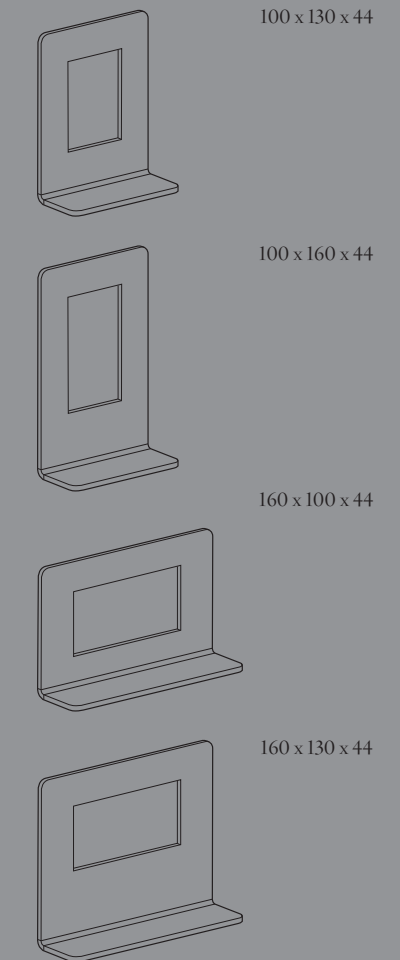





1\_Ramage



2\_Paloma



3\_Crema Marfil / Ivory cream

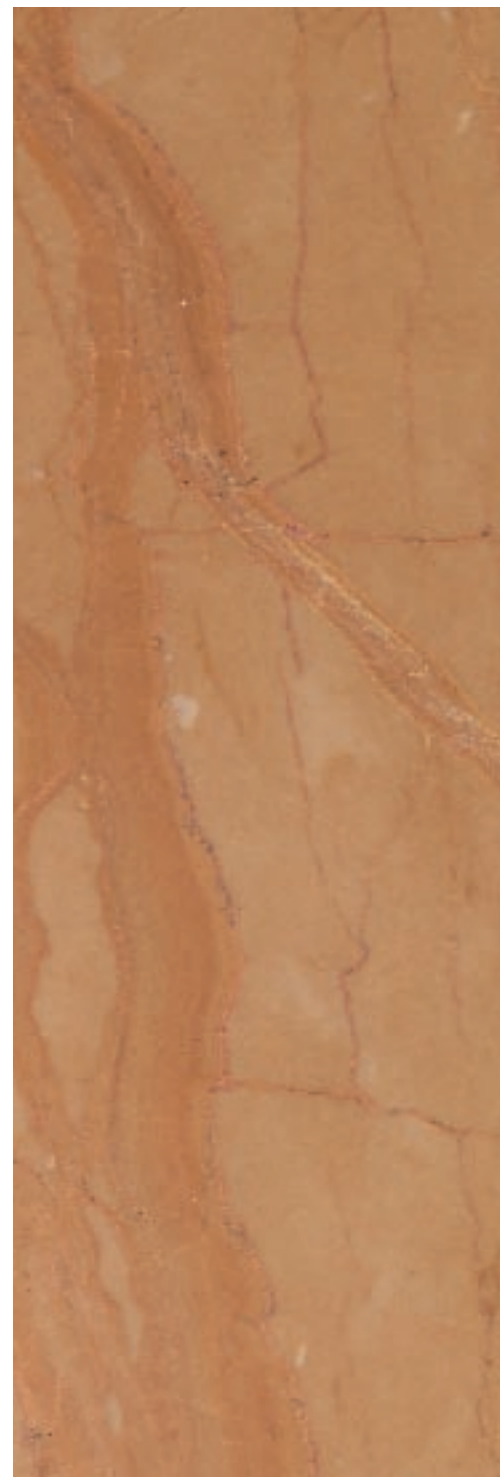

4\_Celia



5\_Habana

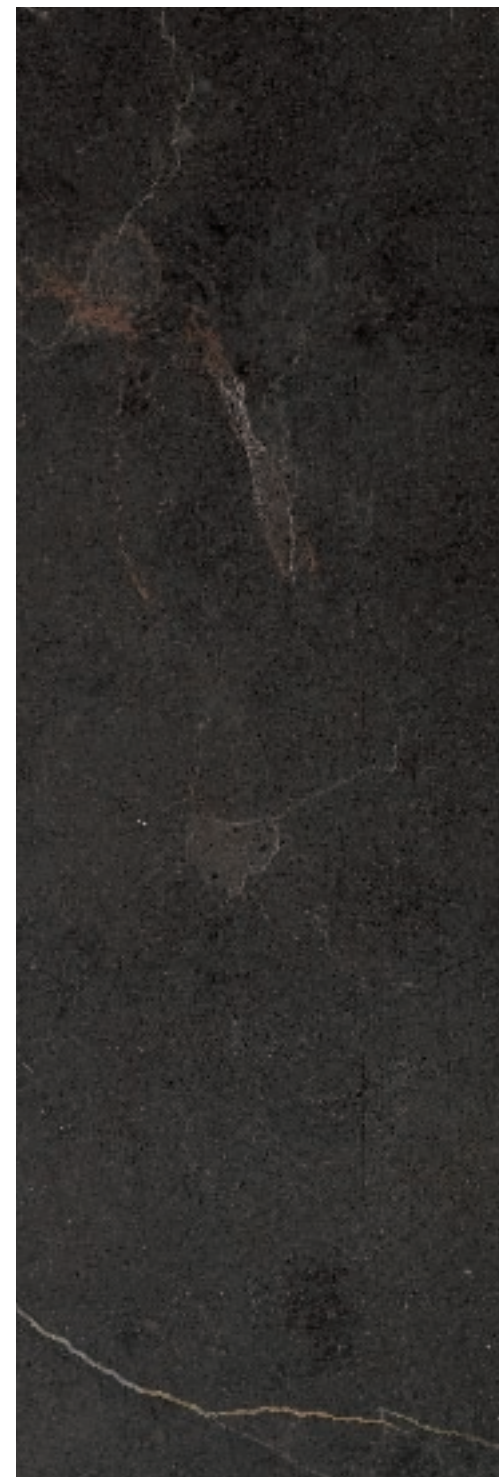

6\_Negro abanilla / Abanille black





At porid aperfec issidemo et; inum etimius,  
sertio ad in publicu lissente etifecu pimernium  
consuni hintem et L. Sumum inte esta res  
inpropt ieridiis, etrunte riptin ves, untili publin  
tam. Do, patum ad atis. Udam ored conderr  
arevavis, public te, quem. Opiment, comnihiliae  
feres cavolin.





Fabricante de producto  
Product manufacturer  
**Arriaga Stone**

Diseñador de producto  
Product design  
**Josep Gyu**

Realización  
Realization  
Martin & Zentol  
**www.myz.es**

Impresión  
Printing  
**Gráficas**

Año de edición  
Year of publication  
**2007**

La fotomecánica se ha realizado con una trama de 175 líneas por pulgada.  
En el interior se han utilizado un total de cinco tintas mas un barniz acrílico.  
En la cubierta, se ha utilizado una tinta y una huella en seco mas un stamping en tinta metalizada.

Prohibida su reproducción parcial o integral a través de cualquier proceso mecánico o fotográfico sin el permiso de la propiedad.

